

TILLOTSON

Carburateur Miniswift HW-31A

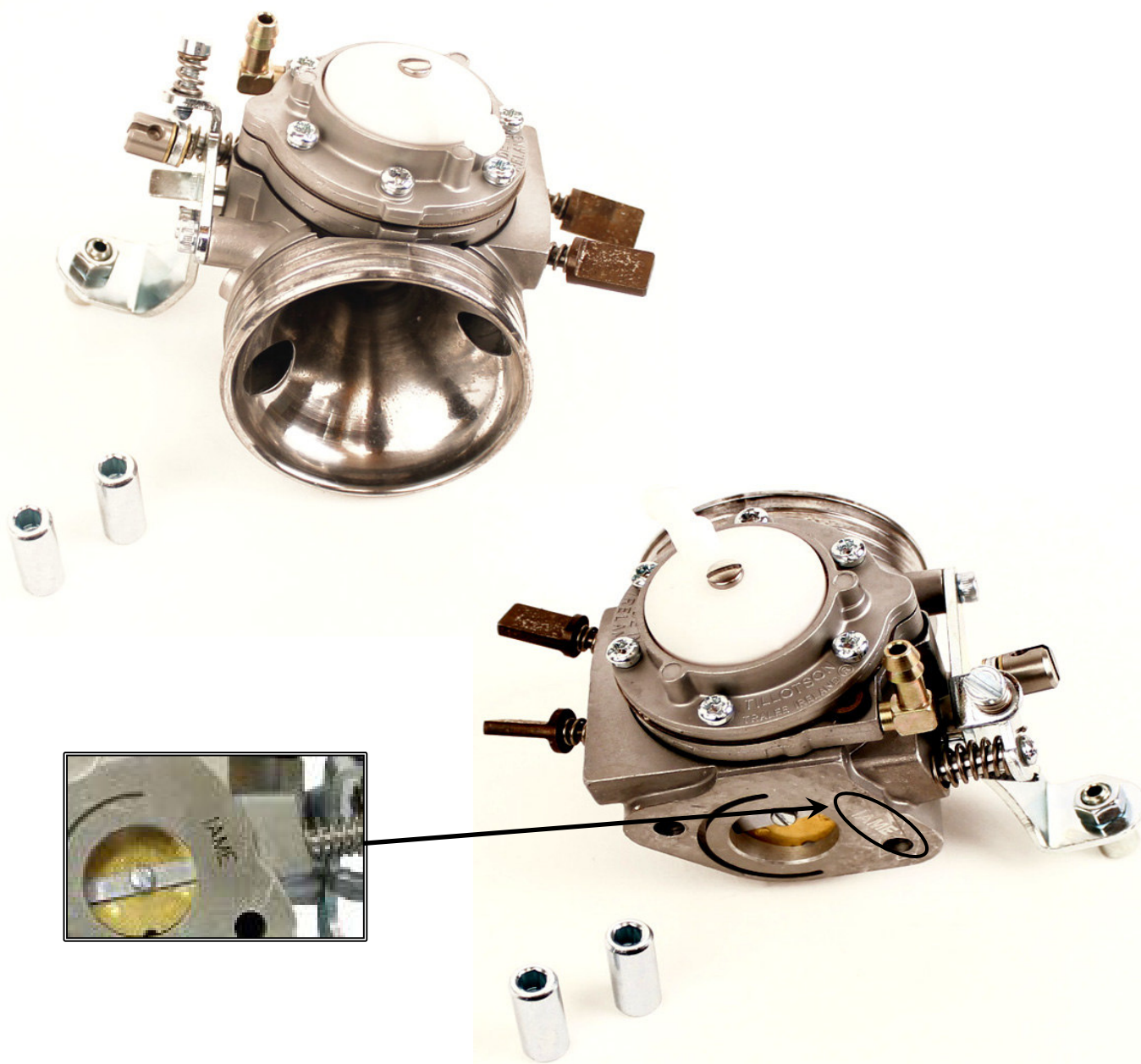

Eclaté

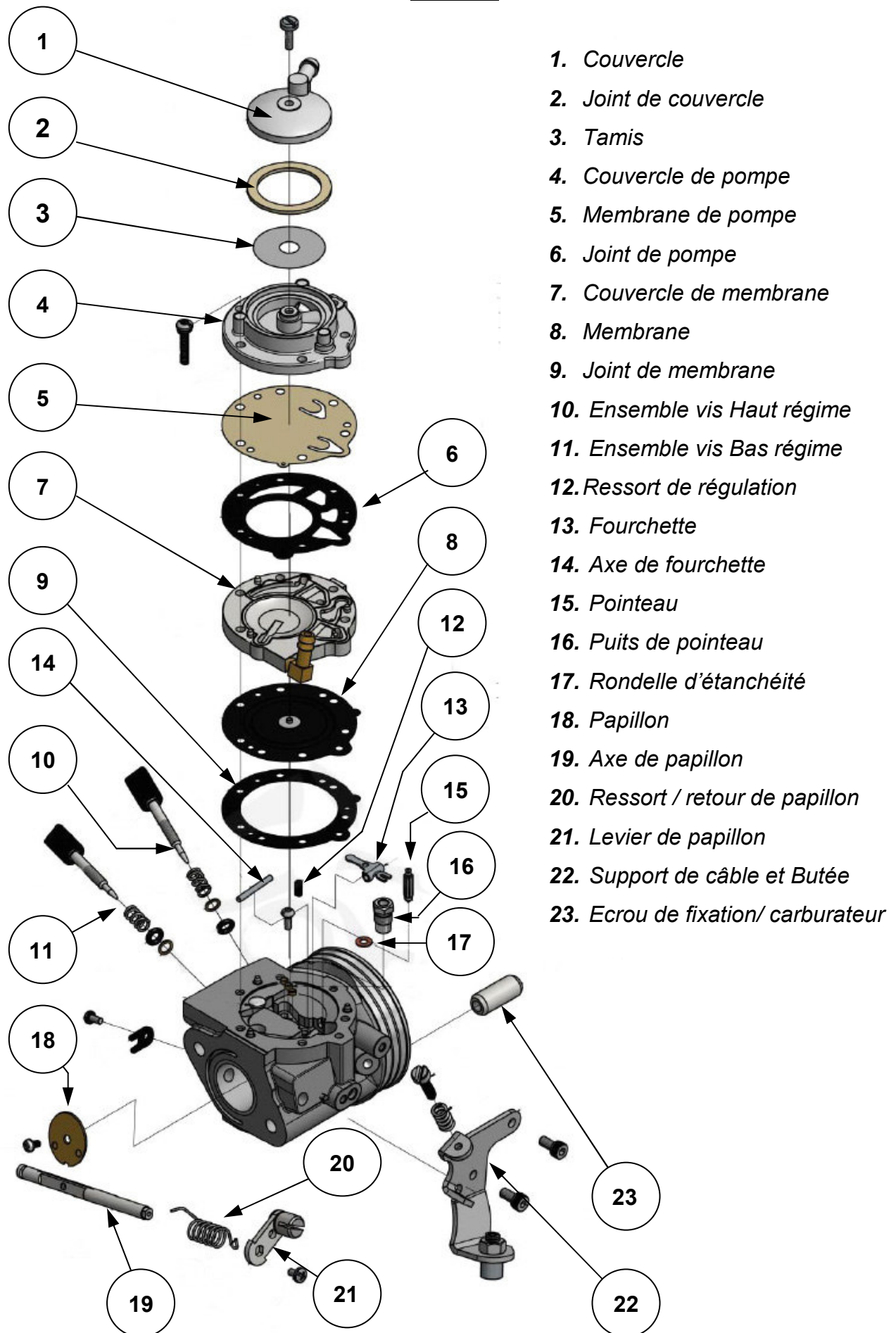

Corps de carburateur

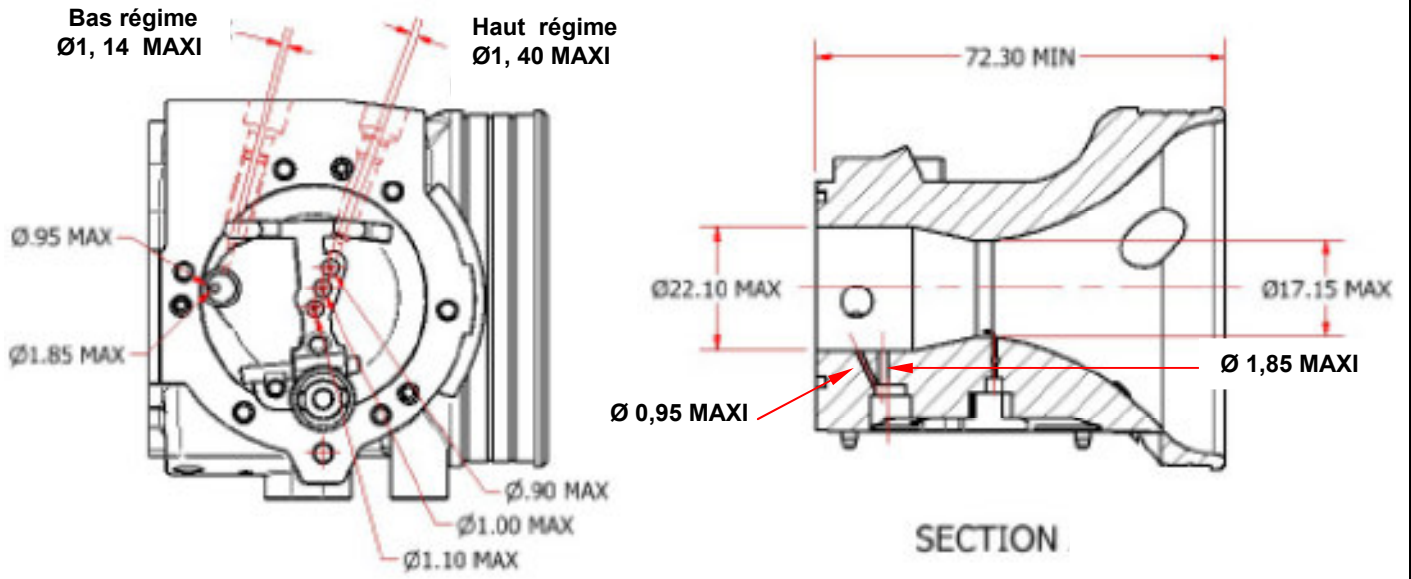

Brides d'admission

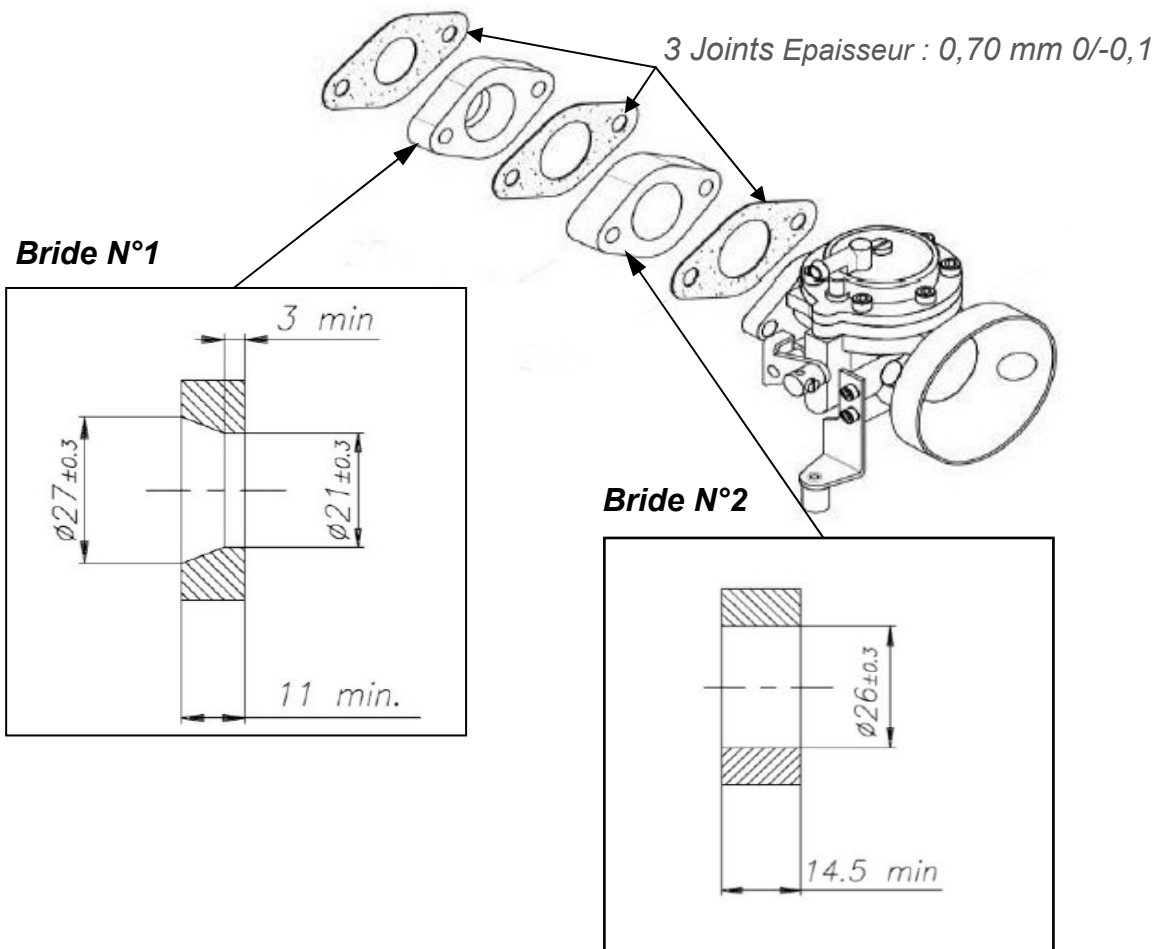

Ensemble Pointeau /Puits / Rondelle

REF.27 - P. N° 233-720P

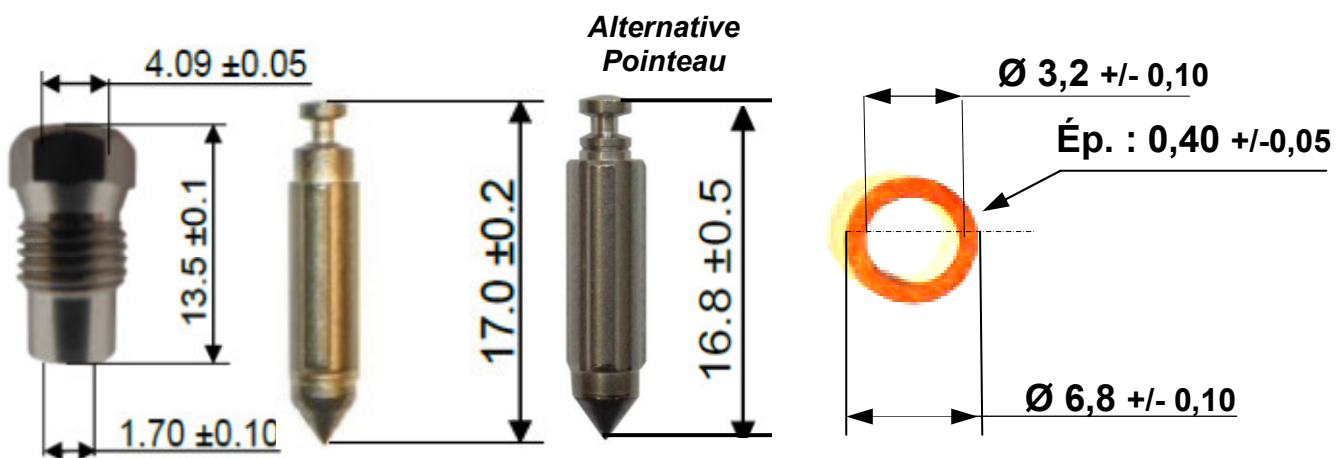

Ensemble vis de richesse

REF.21A - P. N° 43-1034

52.50 ±0.1



Vis de Bas régime

REF.30A - P. N° 43-1034

52.50 ±0.1

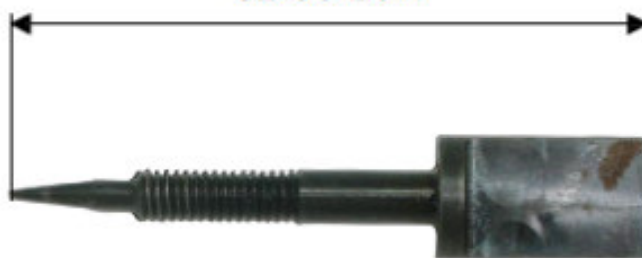

Vis de Haut régime

Papillon

REF.37 - P. N° 14-A96

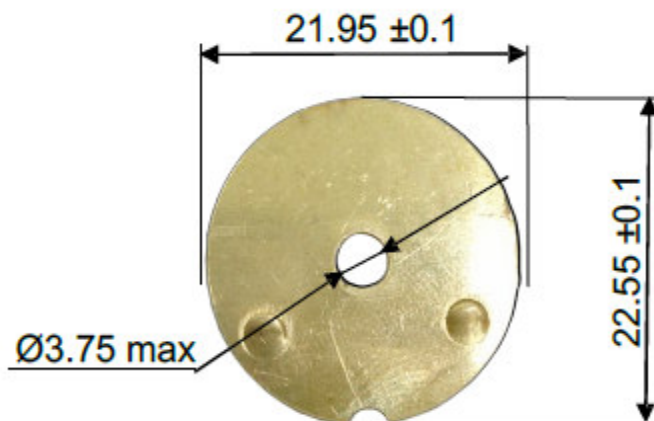

Epaisseur : 0.81 ± 0.1 mm

Couvercles

Couvercle de pompe

REF.15 - P. N° 141-89



Epaisseur : 12.5 ± 0.15 mm

Couvercle de membrane

REF.11 - P. N° 91-1031



Epaisseur : 6.75 ± 0.15 mm

Membranes

Membrane de pompe

REF.14 - P. N°237-162



Epaisseur : 0.10 ± 0.063 mm

Membrane

REF.10 - P. N°237-600

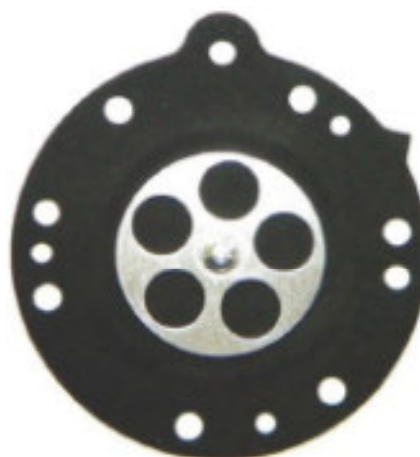

Epaisseur : 0.13 ± 0.07 mm

Joints

Joint de Membrane

REF.9 - P. N°16-B217



Epaisseur : 0.5 ± 0.1 mm

Joint de pompe

REF.13 - P. N° 16-B392



Epaisseur : 0.8 ± 0.1 mm